

COOK CONCRETE PRODUCTS, INC.

—Precast—



MANHOLE PIPE DRAINAGE INLETS STORM WATER / OIL SERARATORS UTILITY VAULTS & BOXES CUSTOM PRECAST

(530) 243-2562
 FAX (530) 243-6881
 www.cookconcreteproducts.com
 e-mail:
 Info@cookconcreteproducts.com

5461 EASTSIDE ROAD
 P.O. BOX 720280
 REDDING, CA 96099

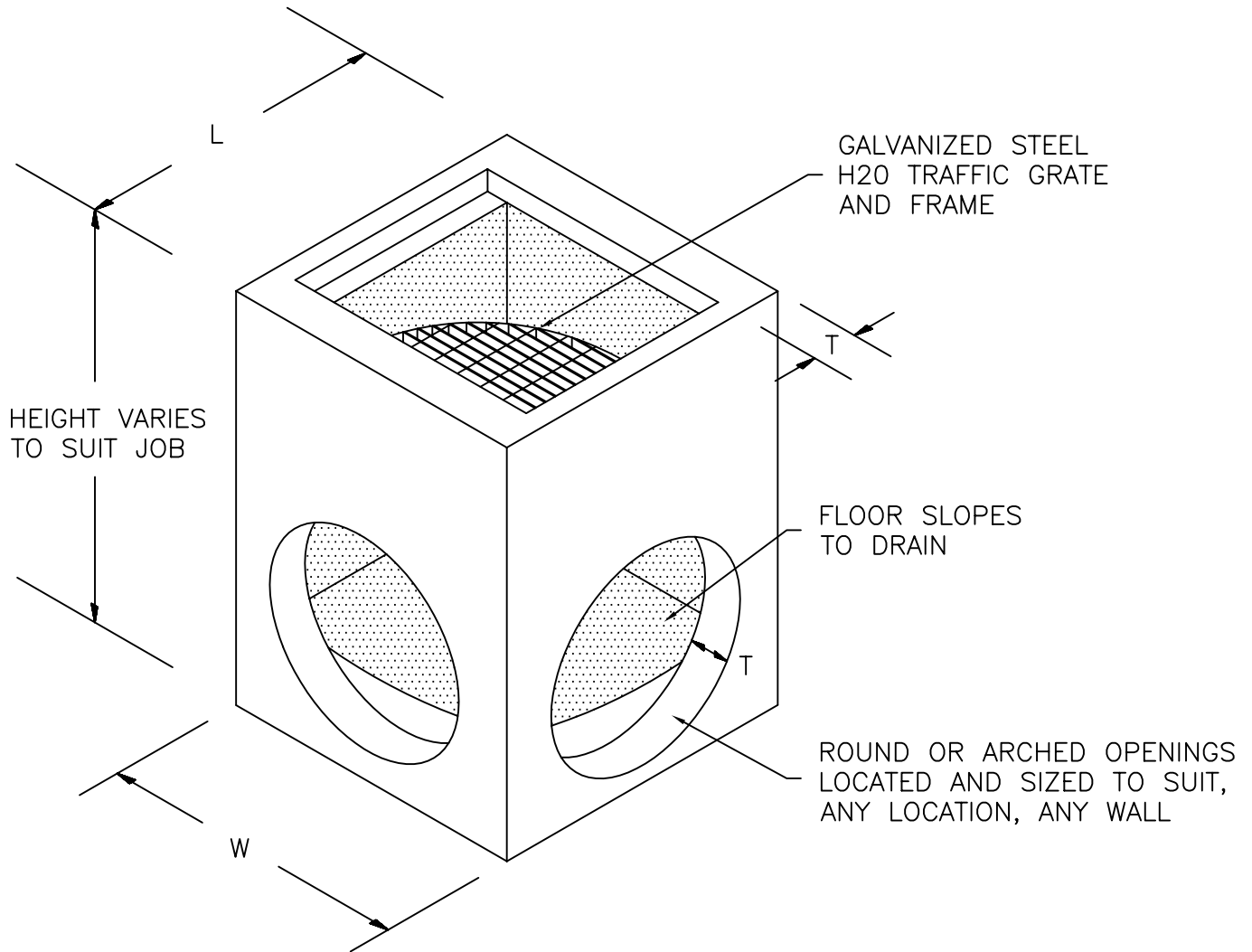

NOTES:

1. CONCRETE COMPRESSIVE STRENGTH 4000 PSI AT 28 DAYS, REINFORCED FOR H-20 LOADING
2. UNITS ARE CUSTOM MADE FOR EACH JOB
3. AVAILABLE WITH OR WITHOUT BOTTOM
4. OPENINGS ARE SIZED AND LOCATED PER PLAN

PRODUCT	DIMENSIONS		
	L	W	T
12" X 12" CATCH BASIN	20"	20"	4"
18" X 18" CATCH BASIN	26"	26"	4"
24" X 24" CATCH BASIN	36"	36"	6"
24" X 48" CATCH BASIN	36"	60"	6"
30" X 30" CATCH BASIN	42"	42"	6"
24" X 36" CATCH BASIN	36"	48"	6"
36" X 38" CATCH BASIN	48"	50"	6"
48" X 48" CATCH BASIN	60"	60"	6"

CATCH BASINS