

COOK CONCRETE PRODUCTS, INC.

—Precast—



MANHOLE PIPE DRAINAGE INLETS STORM WATER / OIL SERARATORS UTILITY VAULTS & BOXES CUSTOM PRECAST

(530) 243-2562
FAX (530) 243-6881
www.cookconcreteproducts.com
e-mail:
Info@cookconcreteproducts.com

5461 EASTSIDE ROAD
P.O. BOX 720280
REDDING, CA 96099

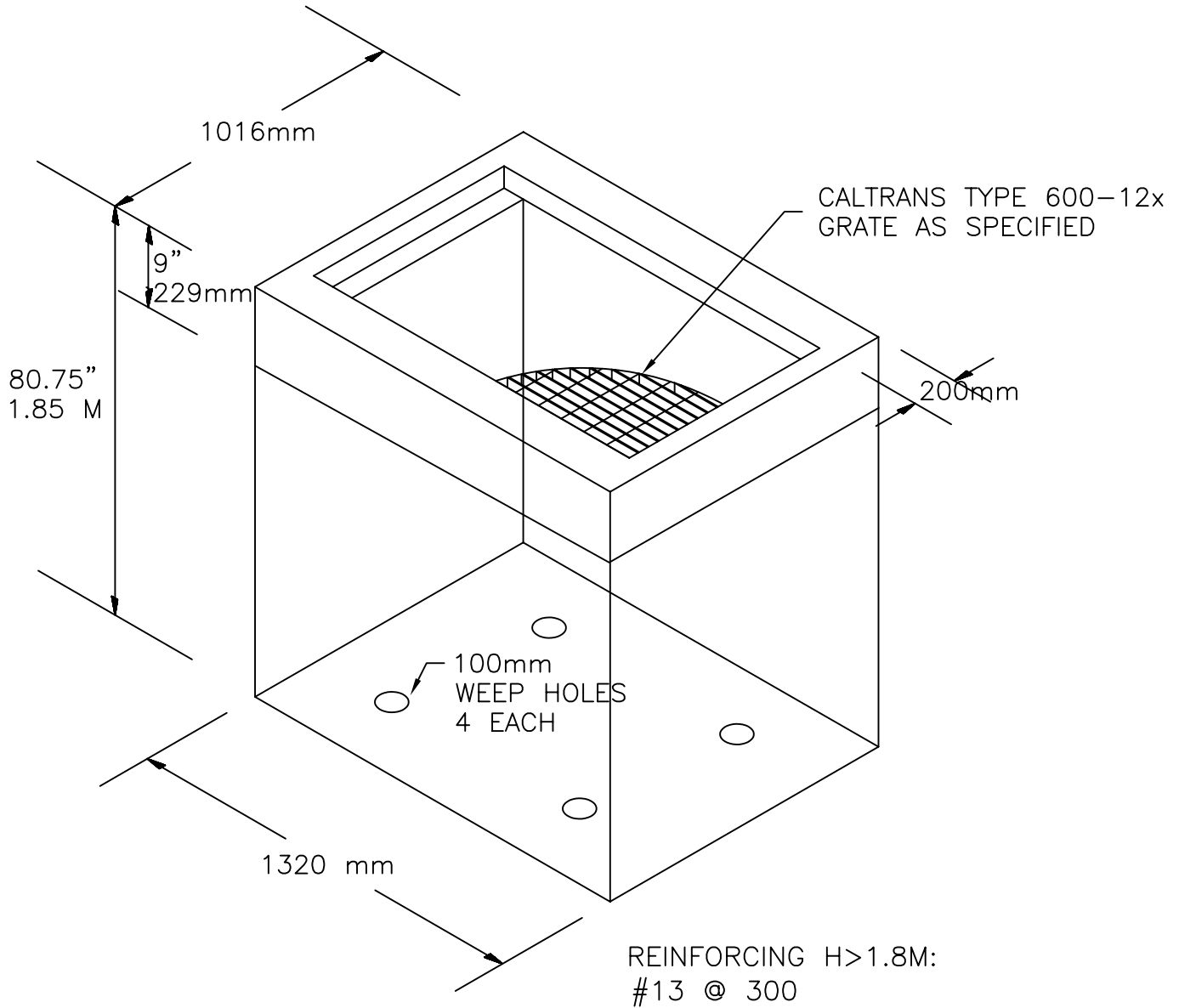

NOTES:

1. UNITS ARE CUSTOM MADE FOR EACH JOB
2. AVAILABLE WITH OR WITHOUT BOTTOM
3. OPENINGS SIZED AND LOCATED PER PLANS
4. WEIGHT WITHOUT BASE 970LBS./FT

TYPE G1/SAND TRAP
600 X 900 AREA DRAIN

APPROVED BY:
CALTRANS
BUTTE COUNTY
CITY OF CHICO