

(530) 243-2562  
FAX (530) 243-6881  
www.cookconcreteproducts.com  
e-mail:  
Info@cookconcreteproducts.com

5461 EASTSIDE ROAD  
P.O. BOX 720280  
REDDING, CA 96099

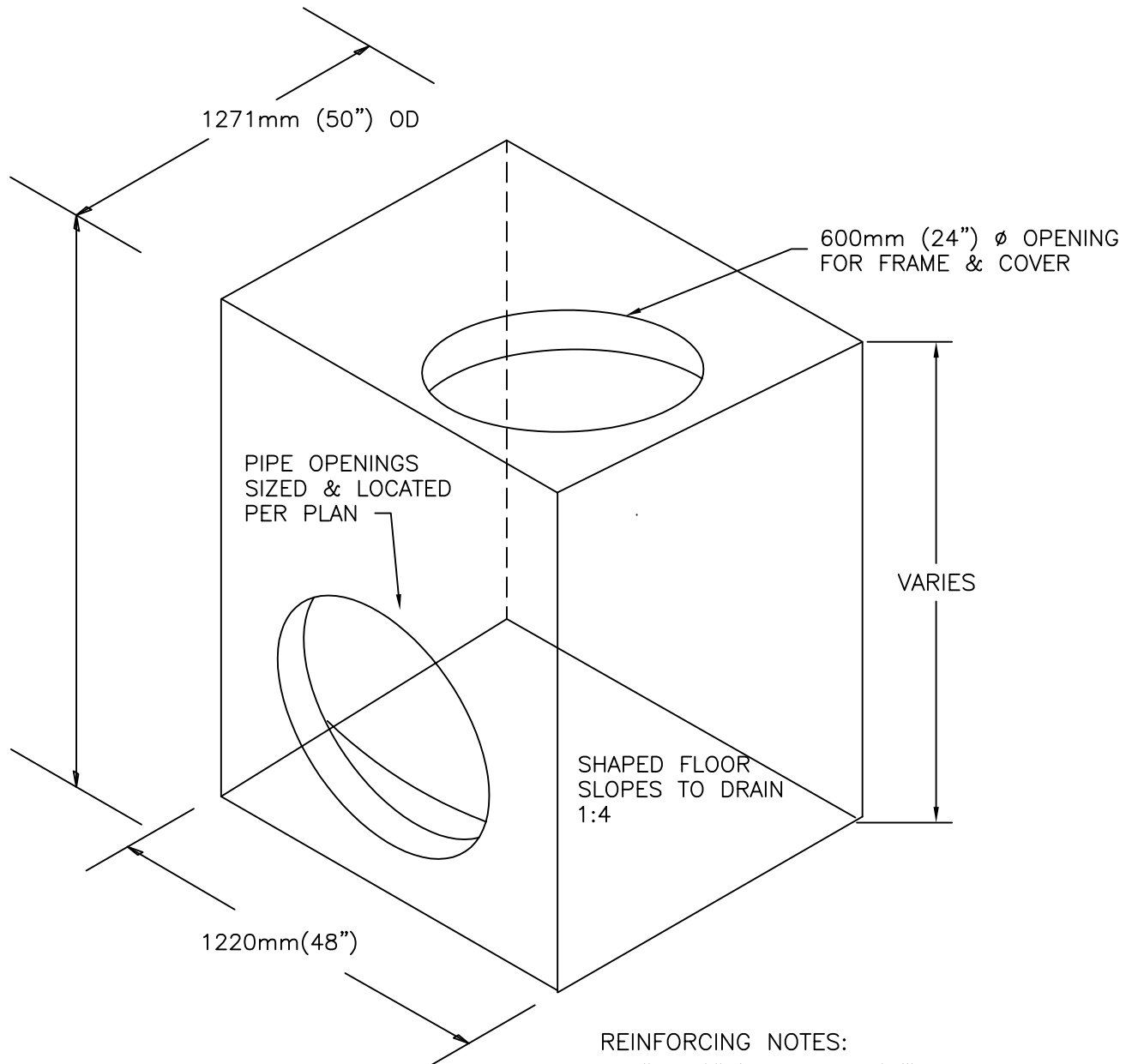

NOTES:

1. WALL THICKNESS 200mm (8") FOR H > 2.51M(8')
2. FLOOR THICKNES 200mm (8")
3. OPENINGS SHALL BE SIZED PER PLAN
4. WEIGHT WITHOUT BASE 1037 LBS./FT

REINFORCING NOTES:

1. #13 (#4) @150mm(6") TOP
2. #22 (#7) @ 200mm (8") BEND INTO WALL.
3. #13 (#4) HOOPS @300mm(12")
4. #22 (#7) DIAGNOLS TOTAL 3

APPROVED BY:  
CALTRANS

TYPE G2 MANHOLE