

MANHOLE PIPE • DRAINAGE INLETS • STORM WATER/OIL INTERCEPTORS • UTILITY VAULTS & BOXES • CUSTOM PRECAST

(530) 243-2562
FAX (530) 243-6881
www.cookconcreteproducts.com
e-mail:
Info@cookconcreteproducts.com

5461 EASTSIDE ROAD
P.O. BOX 720280
REDDING, CA 96099

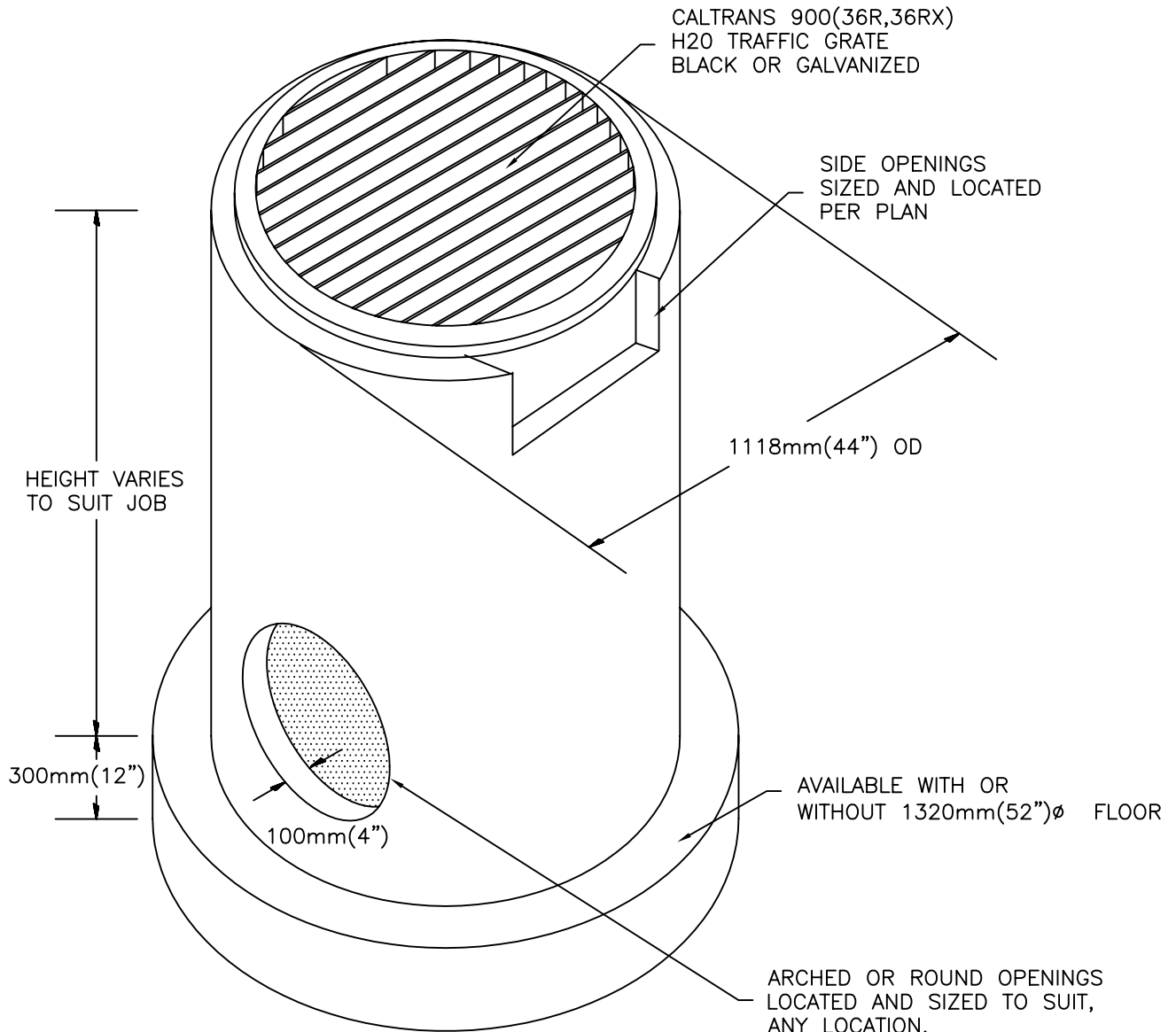

NOTES:

1. CONCRETE COMPRESSIVE STRENGTH
4000 PSI AT 28 DAYS, REINFORCED FOR
H-20 LOADING
2. UNITS ARE CUSTOM MADE FOR EACH JOB
3. OPENINGS SIZED AND LOCATED
PER PLANS
4. WEIGHT WITHOUT BASE 520LBS./FT
BASE WEIGHT 2185LBS.
5. FLOOR SLOPES 12:3 TO OUTLET

GCP 900
(36")Ø AREA DRAIN