

MANHOLE PIPE • DRAINAGE INLETS • STORM WATER/OIL INTERCEPTORS • UTILITY VAULTS & BOXES • CUSTOM PRECAST

(530) 243-2562  
 FAX (530) 243-6881  
 www.cookconcreteproducts.com  
 e-mail:  
 Info@cookconcreteproducts.com

5461 EASTSIDE ROAD  
 P.O. BOX 720280  
 REDDING, CA 96099

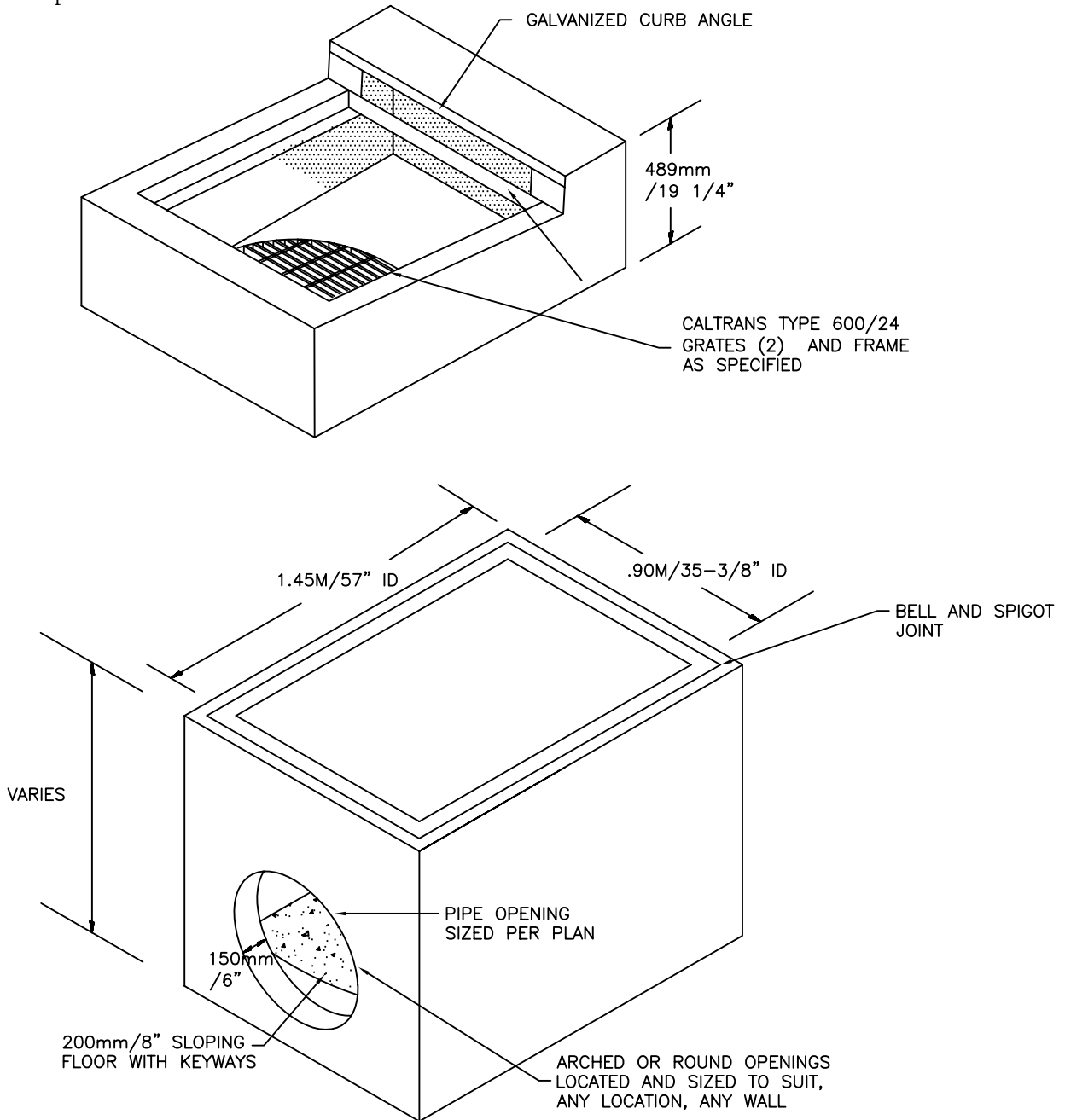

**NOTES:**

1. UNITS ARE CUSTOM MADE FOR EACH JOB
2. SEPARATE TOP FOR GRADE ADJUSTMENT
3. H= $\geq$ .70 STEPS INSTALLED 300 mm SPACING
4. AIR ENTRAINMENT
5. PLAIN FRAME AND GRATES
6. REINFORCING PER CALTRANS STANDARD PLAN D74B

APPROVED BY:  
 CALTRANS

TYPE GDO  
DRAINAGE INLET