

# COOK CONCRETE PRODUCTS, INC.

—Precast—



MANHOLE PIPE • DRAINAGE INLETS • STORM WATER/OIL INTERCEPTORS • UTILITY VAULTS & BOXES • CUSTOM PRECAST

(530) 243-2562  
FAX (530) 243-6881  
www.cookconcreteproducts.com  
e-mail:  
Info@cookconcreteproducts.com

5461 EASTSIDE ROAD  
P.O. BOX 720280  
REDDING, CA 96099

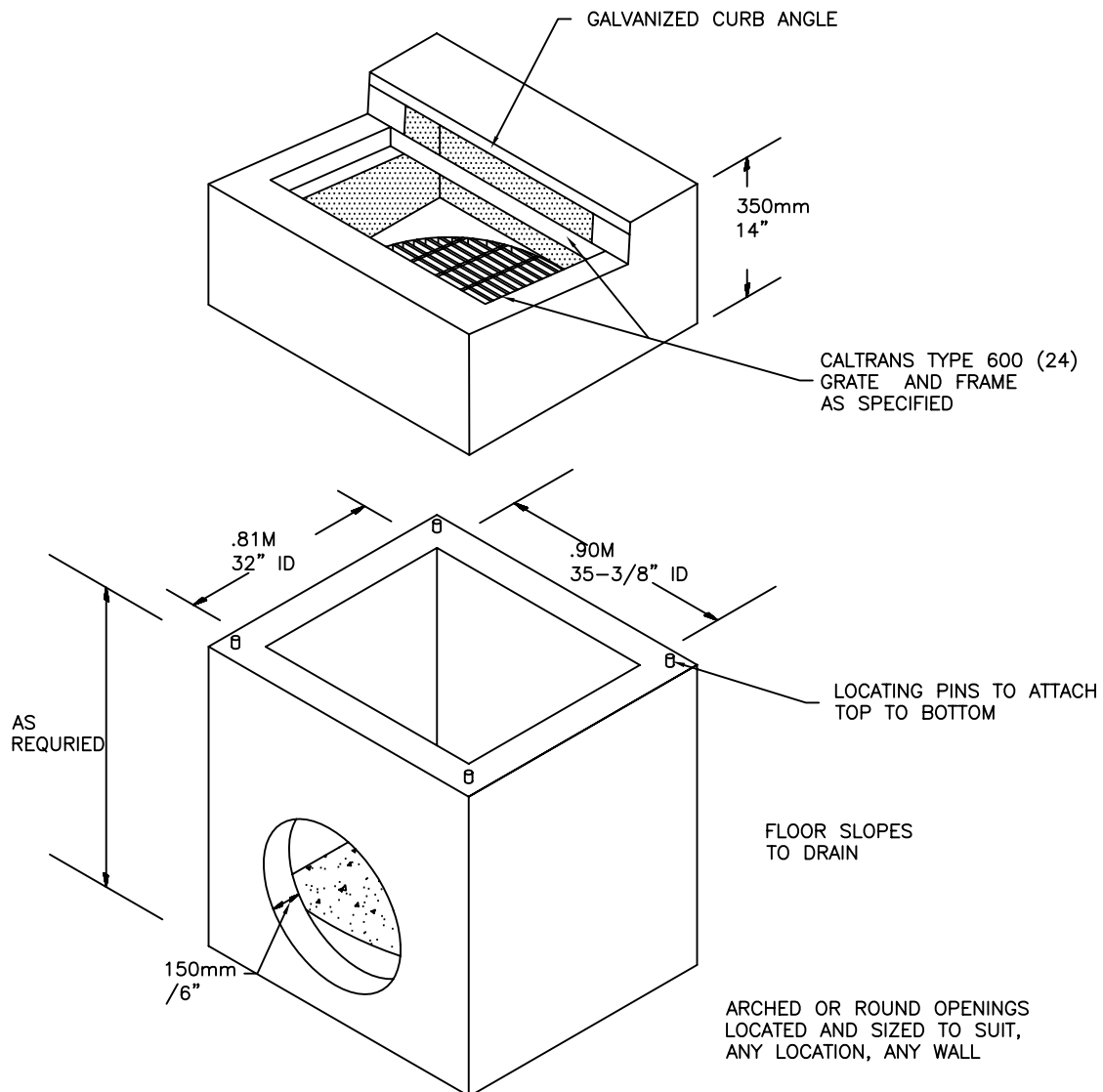

## NOTES:

1. UNITS ARE CUSTOM MADE FOR EACH JOB
2. AVAILABLE WITH OR WITHOUT BOTTOM
3. OPENINGS SHALL BE SIZED AND LOCATED PER PLAN
4. WEIGHT WITHOUT BASE 988LBS./FT
5. AVAILABLE WITH 200mm(8") WALLS

APPROVED BY:  
CALTRANS  
BUTTE COUNTY

TYPE GO  
DRAINAGE INLET