

COOK CONCRETE PRODUCTS, INC.

—Precast—



MEMBER OF

NPCA

Precast ...The Concrete Solution

MANHOLE PIPE • DRAINAGE INLETS • STORM WATER/OIL INTERCEPTORS • UTILITY VAULTS & BOXES • CUSTOM PRECAST

(530) 243-2562

FAX (530) 243-6881

www.cookconcreteproducts.com

e-mail: Info@cookconcreteproducts.com

5461 EASTSIDE ROAD

P.O. BOX 720280

REDDING, CA 96099

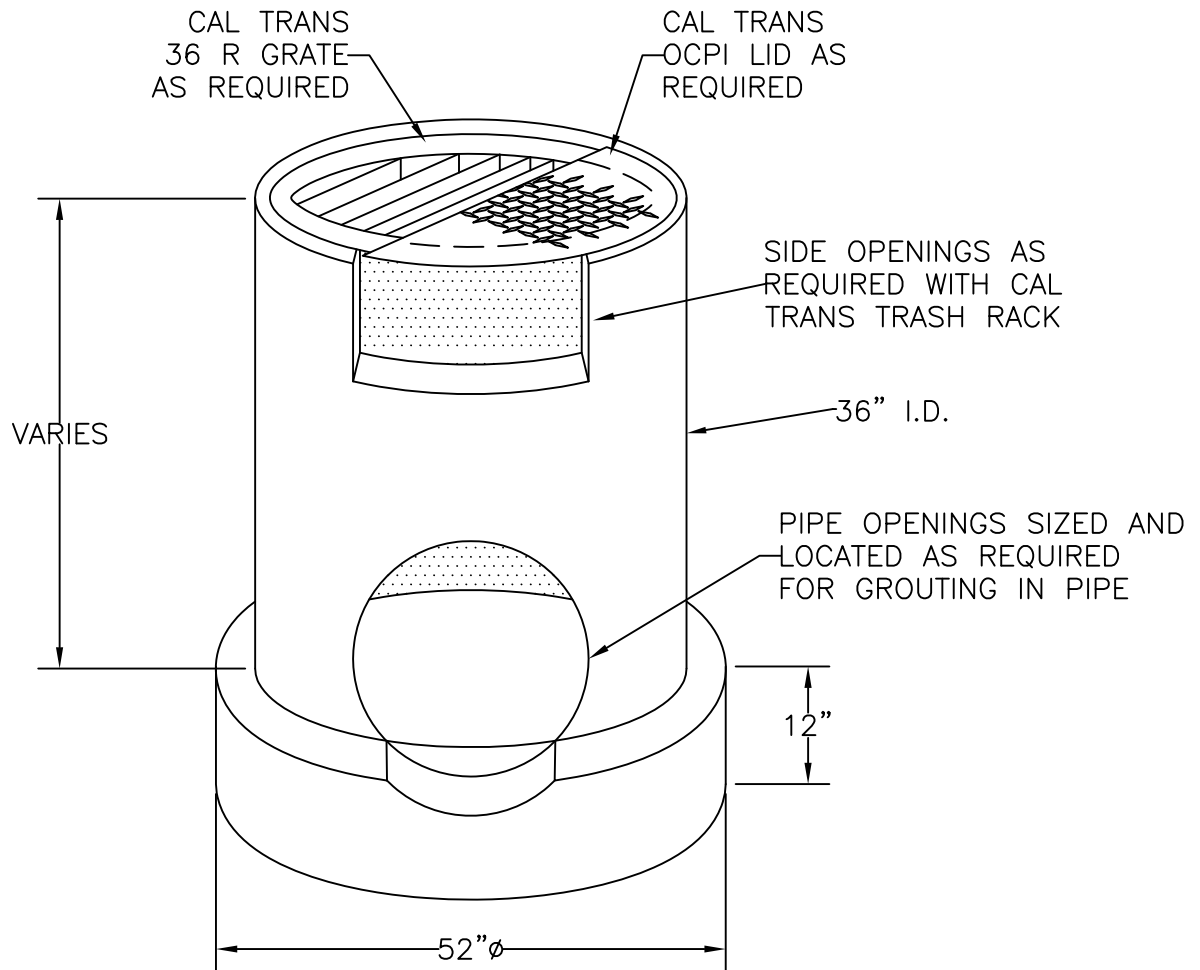

NOTES:

1. MANUFACTURED TO AASHTO M 199M/M 199, AND ASTM C-478 SPECIFICATIONS
2. 4000 PSI CONCRETE
3. FLOOR SLOPES TO OUTLET
4. BOTTOM SLAB, 52"Ø O.D. 12" THICK PER SECTION D-D STD PLANS D75

36" DIAMETER
GCP / OCPI